



Continental Device India Pvt. Limited

An IATF 16949, ISO9001 and ISO 14001 Certified Company



Glass Passivated Bridge Rectifier

Voltage Range - 50 to 1000 Volts Current - 25.0 Ampere

GBJ25XX

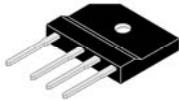

GBJ

GBJ
Plastic Package
RoHS compliant

FEATURES:

1. The plastic material has UL flammability classification 94V-0
2. High surge forward current capability
3. Low forward voltage drop
4. Reliable low cost construction utilizing molded plastic technique results in inexpensive product

APPLICATIONS: General purpose single phase Bridge rectifier applications

ABSOLUTE MAXIMUM RATINGS (Ta = 25 °C Unless otherwise specified)

CHARACTERISTICS	SYMBOLS	GBJ 25005	GBJ 2501	GBJ 2502	GBJ 2504	GBJ 2506	GBJ 2508	GBJ 2510	UNIT
Maximum Recurrent Peak Reverse Voltage	V_{RRM}	50	100	200	400	600	800	1000	V
Maximum RMS Voltage	V_{RMS}	35	70	140	280	420	560	700	V
Maximum DC Blocking Voltage	V_{DC}	50	100	200	400	600	800	1000	V
Maximum Average Forward (with heatsink Note 2)	$I_{(AV)}$	25.0							A
Rectified Current @ $T_C=100$ (without heatsink)		4.2							
Peak Forward Surge Current 8.3ms Single Half Sine-Wave Super Imposed on Rated Load (JEDEC Method)	I_{FSM}	350							A
Maximum Forward Voltage at 12.5A DC	V_F	1.1							V
Maximum DC Reverse Current at Rated DC Blocking Voltage	@ $T_J=25^\circ C$	10.0							μA
	@ $T_J=125^\circ C$	500							
I^2t Rating for Fusing ($t<8.3ms$)	I^2t	510							A^2s
Typical Junction Capacitance Per Element (Note1)	C_J	85							pF
Typical Thermal Resistance (Note 2)	R_{JC}	0.6							$^\circ C/W$
Operating Temperature Range	T_J	-55 to +150							$^\circ C$
Storage Temperature Range	T_{STG}	-55 to +150							$^\circ C$

NOTES:

1. Measured at 1.0MHz and applied reverse voltage of 4.0V DC.
2. Device mounted on 300mm*300mm*1.6mm cu plate heatsink.

GBJ25XX
Rev00_24072020ERC



Continental Device India Pvt. Limited

An IATF 16949, ISO9001 and ISO 14001 Certified Company



TYPICAL CHARACTERISTICS CURVES

Fig 1: Forward Current Derating Curve

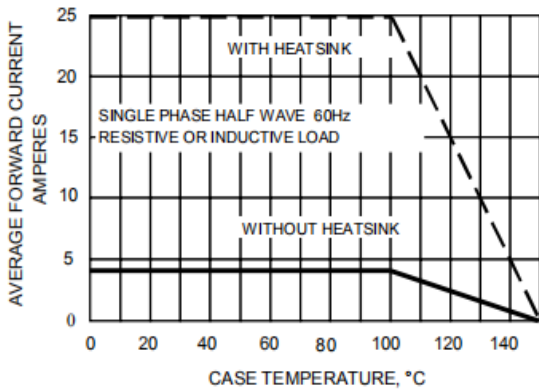

Fig 2: Maximum Non-Repetitive Surge Current

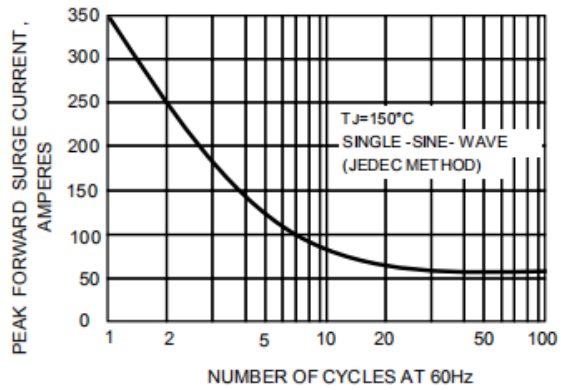

Fig 3: Typical Junction Capacitance

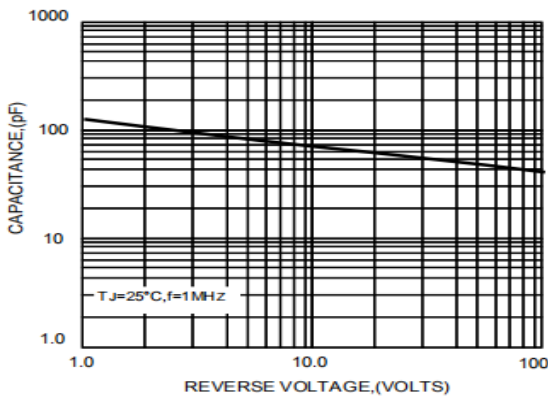

Fig 4: Typical Forward Characteristics

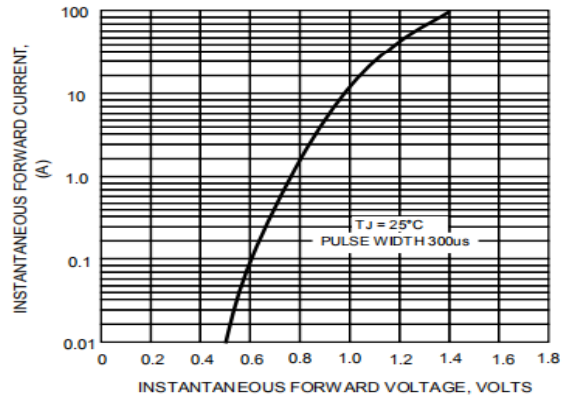
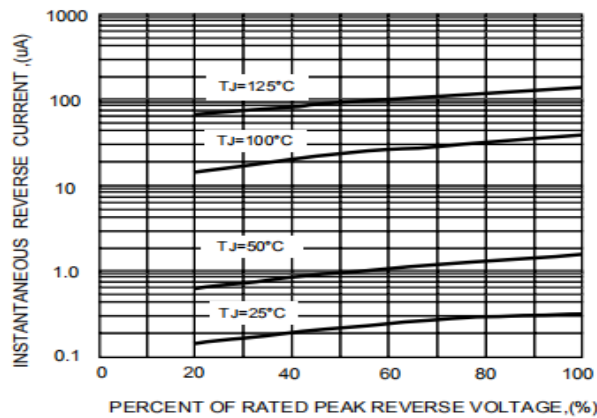

Fig 5: Typical Reverse Characteristics





Continental Device India Pvt. Limited

An IATF 16949, ISO9001 and ISO 14001 Certified Company



PACKAGE DETAILS

GBJ PACKAGE

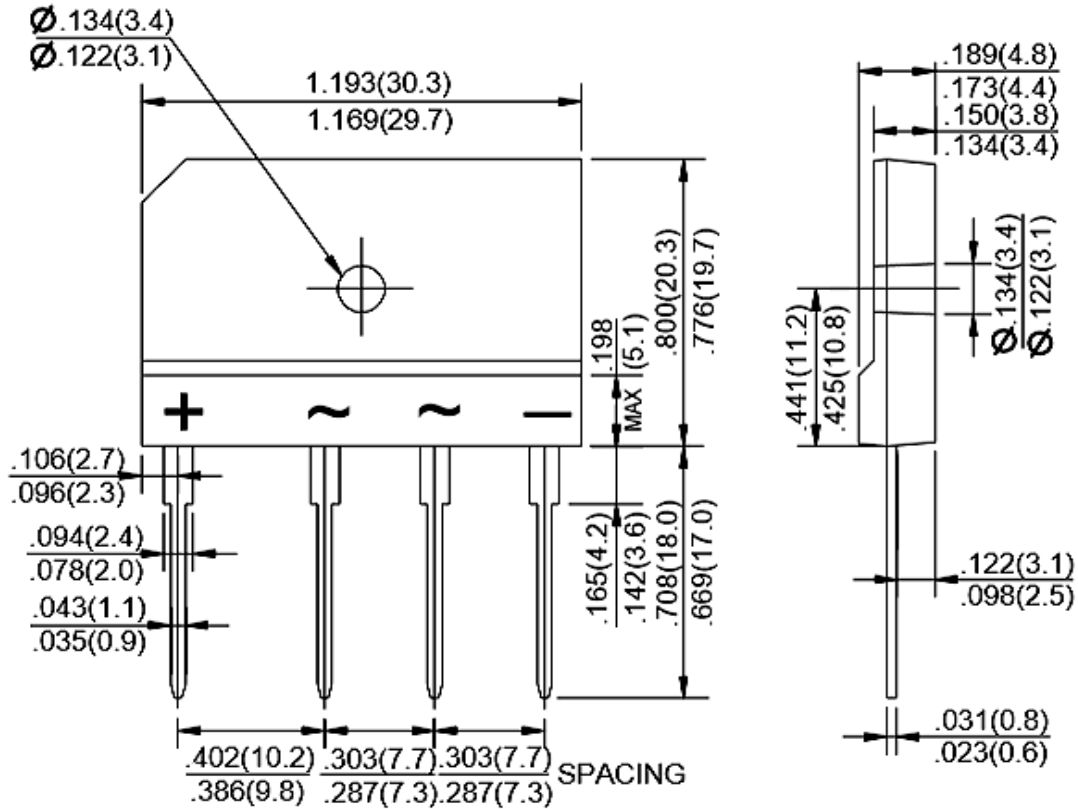

Dimensions in inches and (millimeters)

MECHANICAL DATA

1. Case: Molded plastic body
2. Lead: Solder plated
3. Polarity: As marked

GBJ25XX
Rev00_24072020ERC



Continental Device India Pvt. Limited

An IATF 16949, ISO9001 and ISO 14001 Certified Company



Recommended Product Storage Environment for Discrete Semiconductor Devices

This storage environment assumes that the Diodes and transistors are packed properly inside the original packing supplied by CDIL.

- Temperature 5 °C to 30 °C
- Humidity between 40 to 70 %RH
- Air should be clean.
- Avoid harmful gas or dust.
- Avoid outdoor exposure or storage in areas subject to rain or water spraying .
- Avoid storage in areas subject to corrosive gas or dust. Product shall not be stored in areas exposed to direct sunlight.
- Avoid rapid change of temperature.
- Avoid condensation.
- Mechanical stress such as vibration and impact shall be avoided.
- The product shall not be placed directly on the floor.
- The product shall be stored on a plane area. They should not be turned upside down. They should not be placed against the wall.

Shelf Life of CDIL Products

The shelf life of products is the period from product manufacture to shipment to customers. The product can be unconditionally shipped within this period. The period is defined as 2 years.

If products are stored longer than the shelf life of 2 years the products shall be subjected to quality check as per CDIL quality procedure.

The products are further warranted for another one year after the date of shipment subject to the above conditions in CDIL original packing.

Floor Life of CDIL Products and MSL Level

When the products are opened from the original packing, the floor life will start.

For this, the following JEDEC table may be referred:

JEDEC MSL Level		
Level	Time	Condition
1	Unlimited	≤30 °C / 85% RH
2	1 Year	≤30 °C / 60% RH
2a	4 Weeks	≤30 °C / 60% RH
3	168 Hours	≤30 °C / 60% RH
4	72 Hours	≤30 °C / 60% RH
5	48 Hours	≤30 °C / 60% RH
5a	24 Hours	≤30 °C / 60% RH
6	Time on Label(TOL)	≤30 °C / 60% RH



Continental Device India Pvt. Limited

An IATF 16949, ISO9001 and ISO 14001 Certified Company



Customer Notes

Component Disposal Instructions

1. CDIL Semiconductor Devices are RoHS compliant, customers are requested to please dispose as per prevailing Environmental Legislation of their Country.
2. In Europe, please dispose as per EU Directive 2002/96/EC on Waste Electrical and Electronic Equipment (WEEE).

Disclaimer

The product information and the selection guides facilitate selection of the CDIL's Semiconductor Device(s) best suited for application in your product(s) as per your requirement. It is recommended that you completely review our Data Sheet(s) so as to confirm that the Device(s) meet functionality parameters for your application. The information furnished in the Data Sheet and on the CDIL Web Site/CD are believed to be accurate and reliable. CDIL however, does not assume responsibility for inaccuracies or incomplete information. Furthermore, CDIL does not assume liability whatsoever, arising out of the application or use of any CDIL product; neither does it convey any license under its patent rights nor rights of others. These products are not designed for use in life saving/support appliances or systems. CDIL customers selling these products (either as individual Semiconductor Devices or incorporated in their end products), in any life saving/support appliances or systems or applications do so at their own risk and CDIL will not be responsible for any damages resulting from such sale(s).

CDIL strives for continuous improvement and reserves the right to change the specifications of its products without prior notice.



CDIL is a registered trademark of
Continental Device India Pvt. Limited

C-120 Naraina Industrial Area, New Delhi 110 028, India.

Telephone +91-11-2579 6150, 4141 1112 Fax +91-11-2579 5290, 4141 1119

email@cdil.com www.cdil.com

CIN No. U32109DL1964PTC004291