

NPN HIGH-VOLTAGE TRANSISTOR

CMBT5551



SOT-23

SOT-23
Plastic Package
RoHS compliant

FEATURE:

1. This product is available in AEC-Q101 Qualified and PPAP Capable also.

Note: For AEC-Q101 qualified products, please use suffix -AQ in the part number while ordering.

ABSOLUTE MAXIMUM RATINGS (T_a = 25 °C Unless otherwise specified)

PARAMETER	SYMBOL	VALUE			UNIT
		MIN	TYP	MAX	
Collector–Base voltage (Open Emitter)	V _{CB0}	--	--	180	V
Collector–Emitter voltage (Open Base)	V _{CEO}	--	--	160	V
Collector current	I _C	--	--	600	mA
Total power dissipation up to T _{amb} = 25 °C	P _{tot}	--	--	250	m/W
Junction temperature	T _J	--	--	150	°C
Collector–emitter saturation voltage	V _{CEsat}	--	--	0.2	V
Emitter–base voltage (open collector)	V _{EBO}	--	--	6	V

THERMAL RESISTANCE

From junction to ambient	R _{th j-a}	500	K/W
--------------------------	---------------------	-----	-----

ELECTRICAL CHARACTERISTICS at (T_a = 25 °C Unless otherwise specified)

PARAMETER	SYMBOL	TEST CONDITION	VALUE			UNIT
			MIN	TYP	MAX	
Collector cut-off current	I _{CBO}	I _E = 0; V _{CB} = 120 V	--	--	50	nA
		I _E = 0; V _{CB} = 120 V; T _{amb} = 100 °C	--	--	50	μA
Emitter cut-off current	I _{EBO}	I _C = 0; V _{EB} = 4 V	--	--	50	nA
Breakdown voltages	V _{(BR)CEO}	I _C = 1 mA; I _B = 0	160	--	--	V
	V _{(BR)CBO}	I _C = 100 μA; I _E = 0	180	--	--	
	V _{(BR)EBO}	I _C = 0; I _E = 10 μA	6	--	--	
Saturation voltages	V _{CEsat}	I _C = 10 mA; I _B = 1 mA	--	--	0.15	V
	V _{BEsat}		--	--	1	
	V _{CEsat}	I _C = 50 mA; I _B = 5 mA	--	--	0.2	
	V _{BEsat}		--	--	1	
D.C. current gain	h _{FE}	I _C = 1 mA; V _{CE} = 5 V	80	--	--	
		I _C = 10 mA; V _{CE} = 5 V	80	--	250	
		I _C = 50 mA; V _{CE} = 5 V	30	--	--	
Small-signal current gain	h _{fe}	I _C = 1 mA; V _{CE} = 10 V; f = 1 kHz	50	--	200	
Output capacitance at f = 1 MHz	C _o	I _E = 0; V _{CB} = 10 V	--	--	6	pF
Input capacitance at f = 1 MHz	C _i	I _C = 0; V _{EB} = 0.5 V	--	--	30	pF
Transition frequency at f = 100 MHz	f _T	I _C = 10 mA; V _{CE} = 10 V	100	--	300	MHz

CMBT5551

Rev2_03022024EN

TYPICAL ELECITRICAL CHARACTERISTIC CURVES

Figure 1. DC Current Gain

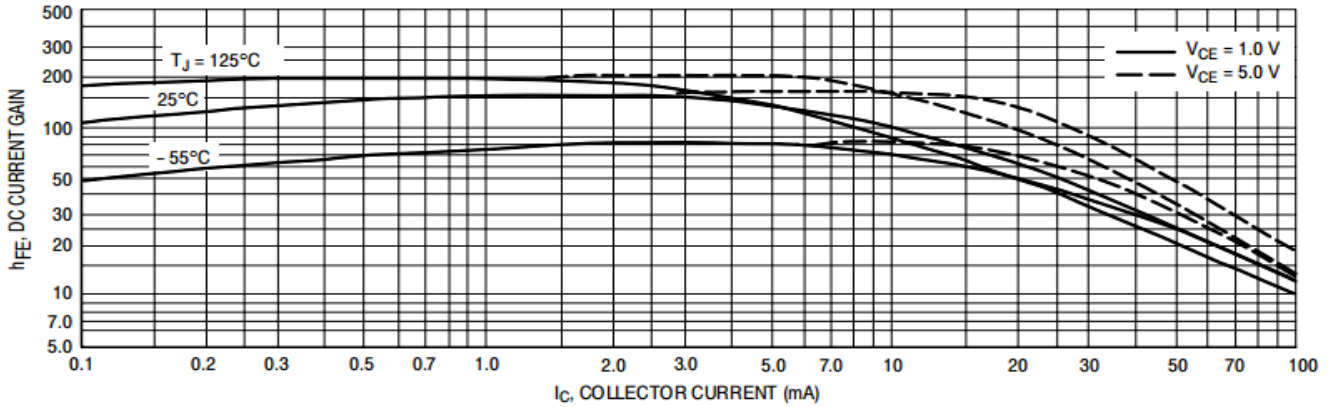

Figure 2. Collector Saturation Region

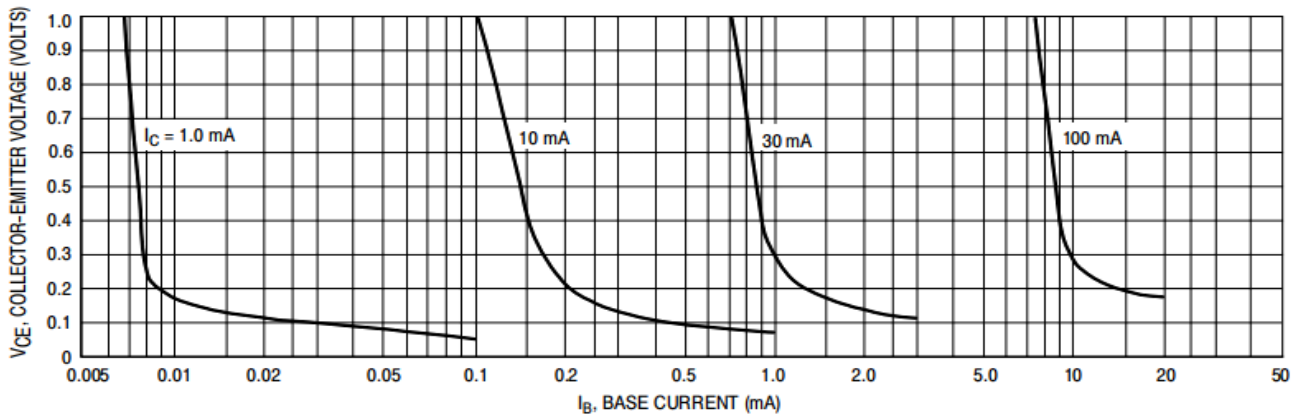

Figure 3. Collector Cut-Off Region

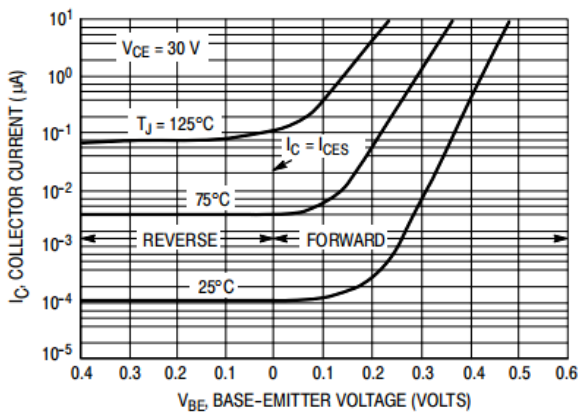
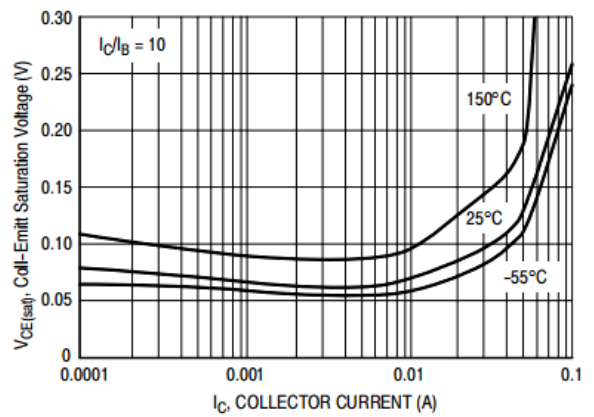

Figure 4. $V_{CE(sat)}$



TYPICAL ELECTRICAL CHARACTERISTIC CURVES

Figure 5. $V_{BE(sat)}$

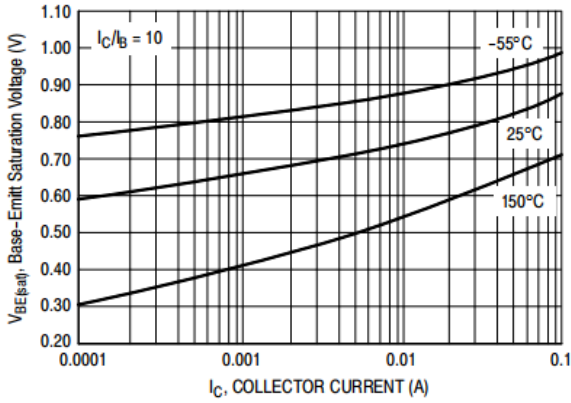

Figure 7. Temperature Coefficients

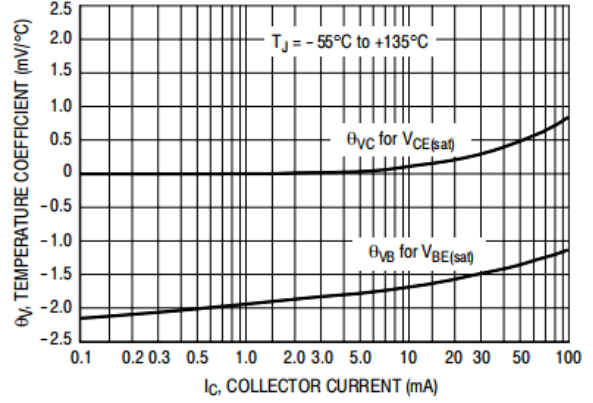

Figure 6. $V_{BE(on)}$

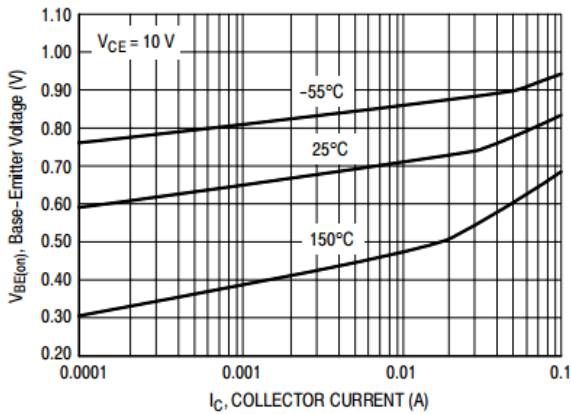

Figure 8. Capacitances

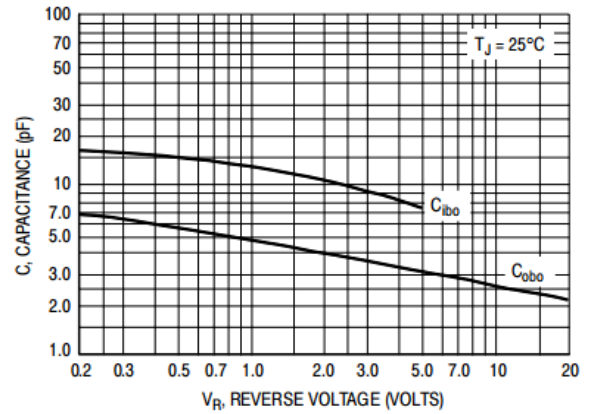
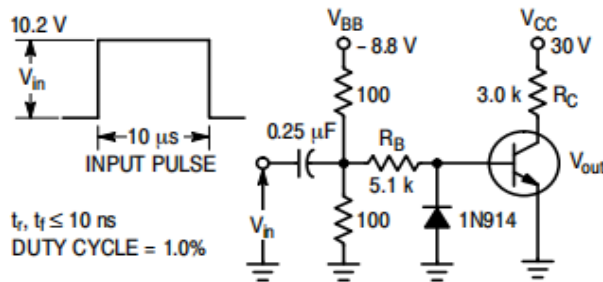

Figure 9. Switching Time Test Circuit



Values Shown are for I_C @ 10 mA

TYPICAL ELECTRIC CHARACTERISTIC CURVES

Figure 10. Current Gain Bandwidth Product

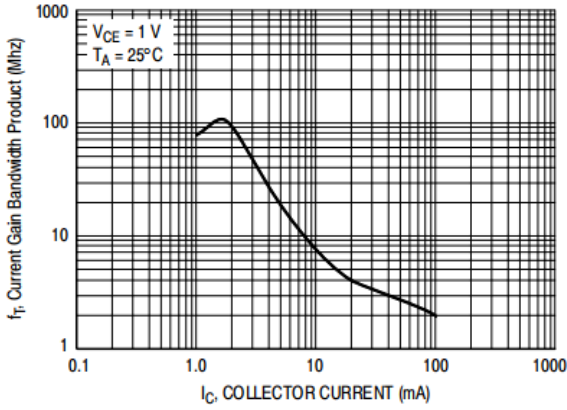

Figure 11. Safe Operating Area

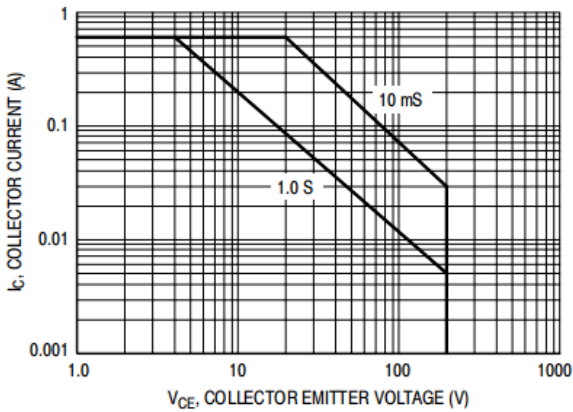

Figure 12. Capacitances

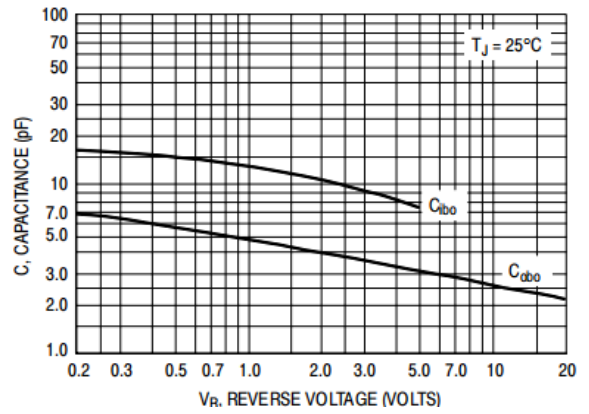
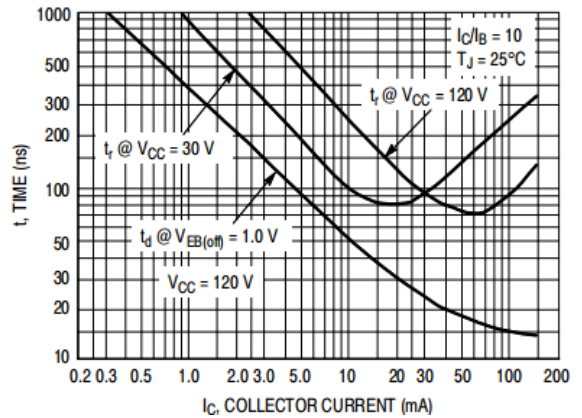
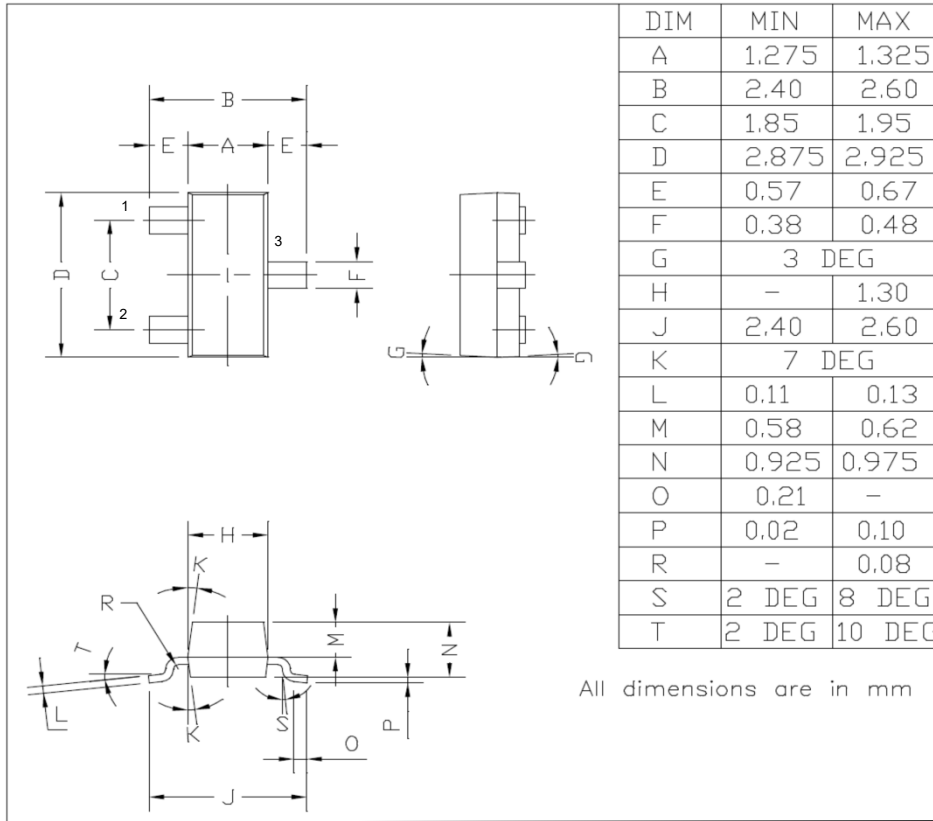

Figure 13. Turn-On Time



PACKAGE DETAILS

SOT-23 SMD Package



Pin configuration

- 1 = BASE
- 2 = EMITTER
- 3 = COLLECTOR

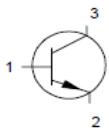

SOT-23 Suggested Pad Layout

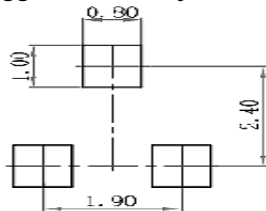

Note

1. Controlling Dimensions: in Millimeters.
2. General Tolerance: $\pm 0.05\text{mm}$
3. The Pad Layout is For Reference Purposes Only.

Reel specifications for Packing (13"/7" reels)

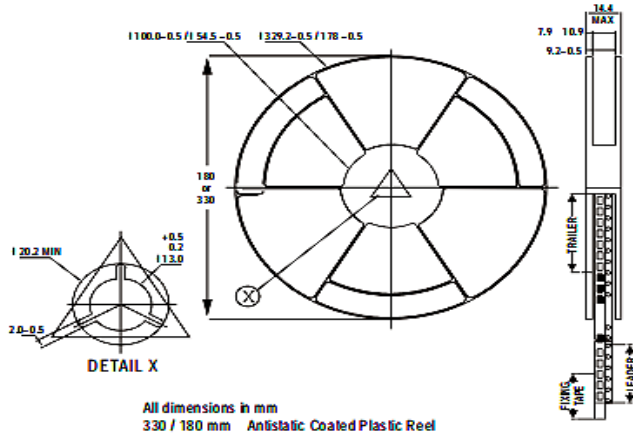

Size of Tape	8mm	8mm
Size of reel	330mm (13")	180mm (7")
No. of Device	10,000 Pcs	3,000 Pcs

NOTES:

1. The bandoier of 330mm reel contains at least 10,000 device.
2. The bandoier of 180mm reel contains at least 3,000 device.
3. No more than 0.5% missing device/reel 50 empty compartments for 330mm reel. 15 empty compartments for 180mm reel.
4. Three consecutive empty places might be found provided this gap is followed by 6 consecutive devices.
5. The carrier tape (leader) starts with at least 75 empty positions (equivalent to 330 mm). In order to fix the carrier tape a self adhesive tape of 20 to 50 mm is applied. At the end of the bandolier at least 40 empty positions (equivalent to 160 mm) are there.

Tape Specification for SOT-23 Surface Mount Device

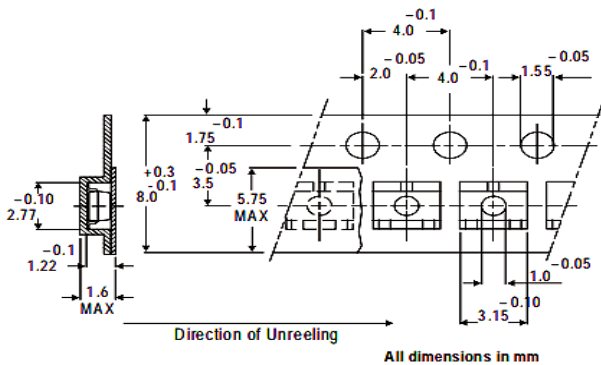

Packing Detail

PACKAGE	STANDARD PACK		INNER CARTON BOX		OUTER CARTON BOX		
	Details	Net Weight/Qty	Size	Qty	Size	Qty	Gr Wt
SOT-23 T&R	3K/reel	136 gm/3K pcs	3" x 7.5" x 7.5"	12.0K	17" x 15" x 13.5"	192.0K	12 kgs
	10K/reel	415 gm/10K pcs	9" x 9" x 9" 13" x 13" x 0.5"	51.0K 10.0K	19" x 19" x 19" 17" x 15" x 13.5"	408.0K 300.0K	28 kgs 16 kgs

Recommended Reflow Solder Profiles

The recommended reflow solder profiles for Pb and Pb-free devices are shown below.

Figure 1 shows the recommended solder profile for devices that have Pb-free terminal plating, and where a Pb-free solder is used.

Figure 2 shows the recommended solder profile for devices with Pb-free terminal plating used with leaded solder, or for devices with leaded terminal plating used with a leaded solder.

Figure 1

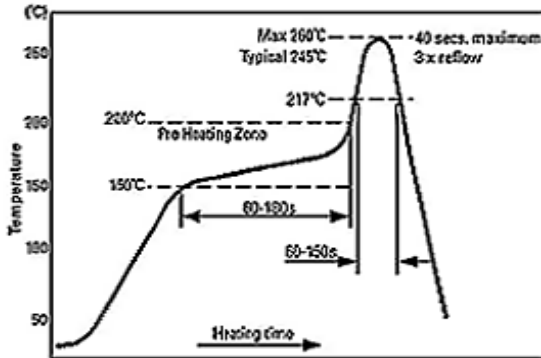
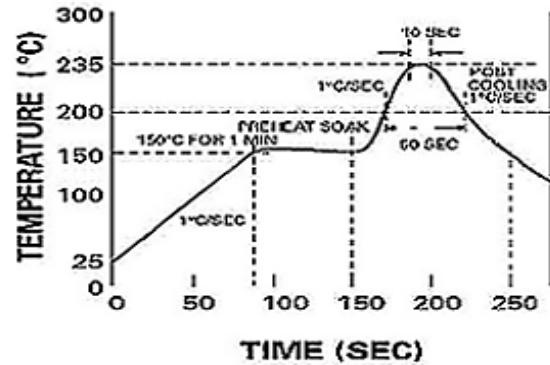

Figure 2



Reflow profiles in tabular form

Profile Feature	Sn-Pb System	Pb-Free System
Average Ramp-Up Rate	~3°C/second	~3°C/second
Preheat		
– Temperature Range	150-170°C	150-200°C
– Time	60-180 seconds	60-180 seconds
Time maintained above:		
– Temperature	200°C	217°C
– Time	30-50 seconds	60-150 seconds
Peak Temperature	235°C	260°C max.
Time within +0 -5°C of actual Peak	10 seconds	40 seconds
Ramp-Down Rate	3°C/second max.	6°C/second max.

Recommended Wave Solder Profiles

The Recommended solder Profile For Devices with Pb-free terminal plating where a Pb-free solder is used

The Recommended solder Profile For Devices with Pb-free terminal plating used with leaded solder, or for devices with leaded terminal plating used with leaded solder

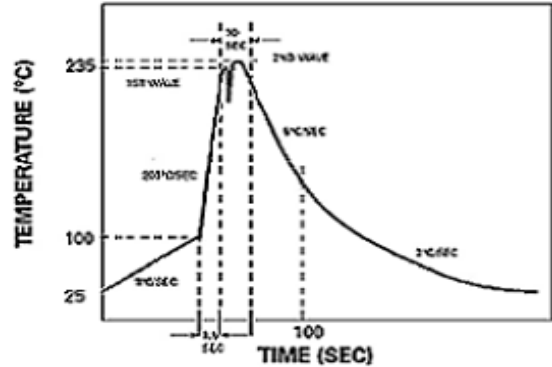
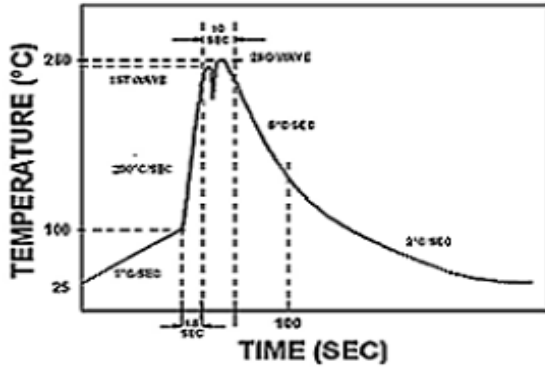

Wave Profiles in Tabular Form

Profile Feature	Sn-Pb System	Pb-Free System
Average Ramp-Up Rate	~200°C/second	~200°C/second
Heating rate during preheat	Typical 1-2, Max 4°C/sec	Typical 1-2, Max 4°C/Sec
Final preheat Temperature	Within 125°C of Solder Temp	Within 125°C of Solder Temp
Peak Temperature	235°C	260°C max.
Time within +0 -5°C of actual Peak	10 seconds	10 seconds
Ramp-Down Rate	5°C/second max.	5°C/second max



Continental Device India Pvt. Limited

An IATF 16949, ISO9001 and ISO 14001/ISO 45001 Certified Company



Recommended Product Storage Environment for Discrete Semiconductor Devices

This storage environment assumes that the Diodes and transistors are packed properly inside the original packing supplied by CDIL.

- Temperature 5 °C to 30 °C
- Humidity between 40 to 70 %RH
- Air should be clean.
- Avoid harmful gas or dust.
- Avoid outdoor exposure or storage in areas subject to rain or water spraying .
- Avoid storage in areas subject to corrosive gas or dust. Product shall not be stored in areas exposed to direct sunlight.
- Avoid rapid change of temperature.
- Avoid condensation.
- Mechanical stress such as vibration and impact shall be avoided.
- The product shall not be placed directly on the floor.
- The product shall be stored on a plane area. They should not be turned upside down. They should not be placed against the wall.

Shelf Life of CDIL Products

The shelf life of products is the period from product manufacture to shipment to customers. The product can be unconditionally shipped within this period. The period is defined as 2 years.

If products are stored longer than the shelf life of 2 years the products shall be subjected to quality check as per CDIL quality procedure.

The products are further warranted for another one year after the date of shipment subject to the above conditions in CDIL original packing.

Floor Life of CDIL Products and MSL Level

When the products are opened from the original packing, the floor life will start.

For this, the following JEDEC table may be referred:

JEDEC MSL Level		
Level	Time	Condition
1	Unlimited	≤30 °C / 85% RH
2	1 Year	≤30 °C / 60% RH
2a	4 Weeks	≤30 °C / 60% RH
3	168 Hours	≤30 °C / 60% RH
4	72 Hours	≤30 °C / 60% RH
5	48 Hours	≤30 °C / 60% RH
5a	24 Hours	≤30 °C / 60% RH
6	Time on Label(TOL)	≤30 °C / 60% RH



Continental Device India Pvt. Limited

An IATF 16949, ISO9001 and ISO 14001/ISO 45001 Certified Company



Customer Notes

Component Disposal Instructions

1. CDIL Semiconductor Devices are RoHS compliant, customers are requested to please dispose as per prevailing Environmental Legislation of their Country.
2. In Europe, please dispose as per EU Directive 2002/96/EC on Waste Electrical and Electronic Equipment (WEEE).

Disclaimer

The product information and the selection guides facilitate selection of the CDIL's Semiconductor Device(s) best suited for application in your product(s) as per your requirement. It is recommended that you completely review our Data Sheet(s) so as to confirm that the Device(s) meet functionality parameters for your application. The information furnished in the Data Sheet and on the CDIL Web Site/CD are believed to be accurate and reliable. CDIL however, does not assume responsibility for inaccuracies or incomplete information. Furthermore, CDIL does not assume liability whatsoever, arising out of the application or use of any CDIL product; neither does it convey any license under its patent rights nor rights of others. These products are not designed for use in life saving/support appliances or systems. CDIL customers selling these products (either as individual Semiconductor Devices or incorporated in their end products), in any life saving/support appliances or systems or applications do so at their own risk and CDIL will not be responsible for any damages resulting from such sale(s).

CDIL strives for continuous improvement and reserves the right to change the specifications of its products without prior notice.



CDIL is a registered trademark of

Continental Device India Pvt. Limited

C-120 Naraina Industrial Area, New Delhi 110 028, India.

Telephone +91-11-2579 6150, 4141 1112 Fax +91-11-2579 5290, 4141 1119

email@cdil.com www.cdil.com

CIN No. U32109DL1964PTC004291

CMBT5551

Rev2_03022024EN