



Continental Device India Pvt. Limited

An IATF 16949, ISO9001 and ISO 14001 Certified Company



Silicon PNP POWER Transistors

CSA1006, CSA1006B



TO-220

TO-220
Leaded Plastic
Package
RoHS compliant

Applications:

1. Audio frequency power amplifier
2. High frequency power amplifier

ABSOLUTE MAXIMUM RATINGS ($T_a = 25 \text{ }^\circ\text{C}$)

Parameter		Symbol	Value	Unit
Collector-Base Voltage	CSA1006	V_{CBO}	-180	V
	CSA1006B		-250	
Collector-Emitter Voltage	CSA1006	V_{CEO}	-180	V
	CSA1006B		-250	
Emitter-Base Voltage		V_{EBO}	-5	V
Collector Current		I_C	-1.5	A
Collector Current--Peak		I_{CM}	-3	A
Total Dissipation		P_{tot}	25	W
Max. Operating Junction Temperature		T_j	150	$^\circ\text{C}$
Storage Temperature		T_{stg}	-55~150	$^\circ\text{C}$



Continental Device India Pvt. Limited

An IATF 16949, ISO9001 and ISO 14001 Certified Company



ELECTRICAL CHARACTERISTICS at $T_a = 25\text{ }^{\circ}\text{C}$

Parameter		Symbol	Test Conditions	Value			Unit
				Min.	Typ.	Max.	
Collector Cut-off Current	CSA1006	I_{CBO}	$V_{CB} = 180V, I_E = 0$	--	--	-1	μA
	CSA1006B		$V_{CB} = -250V, I_E = 0$	--	--	-1	μA
Emitter Cut-off Current	CSA1006	I_{EBO}	$V_{EB} = 5.0V, I_C = 0$	--	--	-1	μA
	CSA1006B		$V_{EB} = -5.0V, I_C = 0$	--	--	-1	μA
Collector-Emitter Sustaining Voltage	CSA1006	V_{CEO}	$I_C = 10mA, I_B = 0$	-180	--	--	V
	CSA1006B			-250	--	--	V
DC Current Gain	CSA1006	$h_{FE}^{(1)}$	$V_{CE} = 5.0V,$ $I_C = 150mA$	60	--	320	
	CSA1006B						
	CSA1006	$h_{FE}^{(2)}$	$V_{CE} = 5.0V,$ $I_C = 5.0mA$	30	--	--	
	CSA1006B						
Collector-Emitter Saturation Voltage	CSA1006	$V_{CE(sat)}$	$I_C = 500mA, I_B = 50mA$	--	--	-1	V
	CSA1006B						
Base-Emitter saturation Voltage	CSA1006	$V_{BE(sat)}$	$I_C = 500mA,$ $I_B = 50mA$	--	--	-1.5	V
	CSA1006B						
Current Gain Bandwidth Product	CSA1006	f_T	$V_{CE} = 10V,$ $I_C = 100mA$	--	80	--	MHz
	CSA1006B						



Continental Device India Pvt. Limited

An IATF 16949, ISO9001 and ISO 14001 Certified Company



Typical Characteristic curves

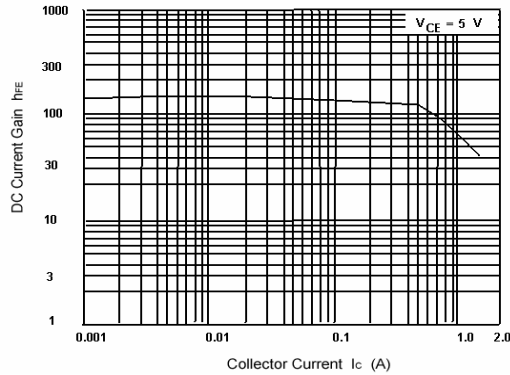

Fig. 1. Current Gain

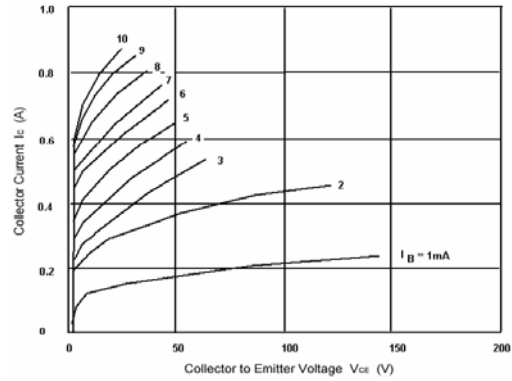

Fig. 2. Static Characteristic

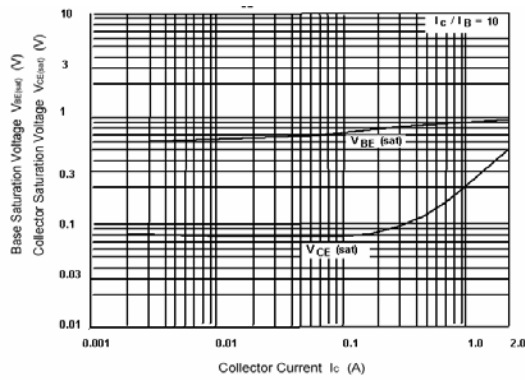

Fig. 3. Base-Emitter, Base-Collect saturation voltage

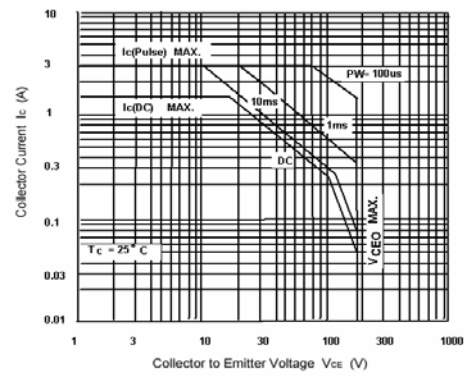

Fig. 4. Safe Operating Area



Continental Device India Pvt. Limited

An IATF 16949, ISO9001 and ISO 14001 Certified Company



Package Details

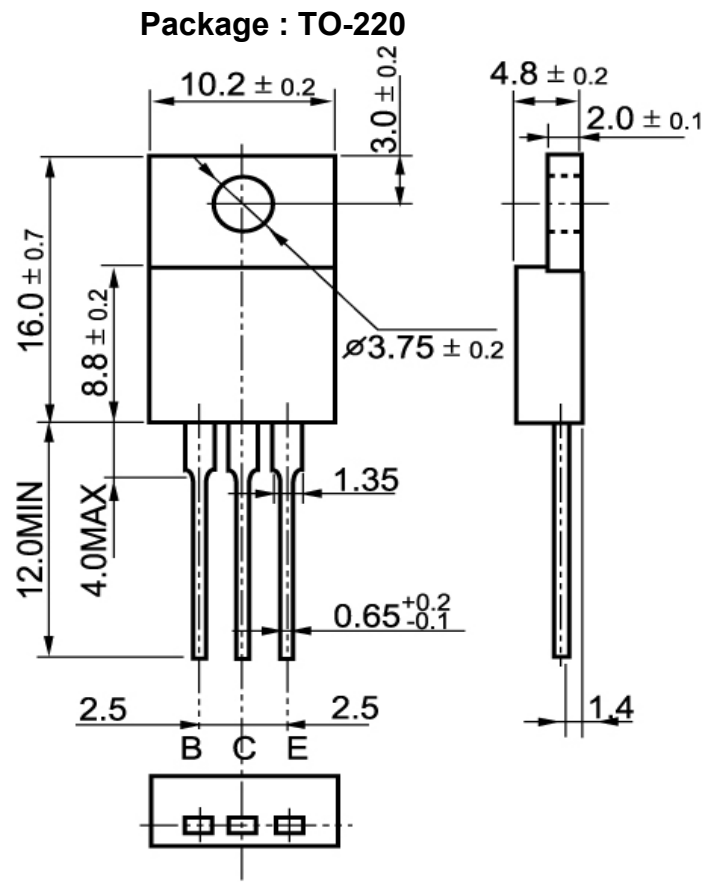

All dimensions are in mm

Note: For AECQ compliant products, please suffix -AH in the part number while ordering



Continental Device India Pvt. Limited

An IATF 16949, ISO9001 and ISO 14001 Certified Company



Recommended Product Storage Environment for Diode and Transistors

This storage environment assumes that the Diodes and transistors are packed properly inside the original packing supplied by CDIL.

- Temperature 5 °C to 30 °C
- Humidity between 40 to 70 %RH
- Air should be clean.
- Avoid harmful gas or dust.
- Avoid outdoor exposure or storage in areas subject to rain or water spraying .
- Avoid storage in areas subject to corrosive gas or dust. Product shall not be stored in areas exposed to direct sunlight.
- Avoid rapid change of temperature.
- Avoid condensation.
- Mechanical stress such as vibration and impact shall be avoided.
- The product shall not be placed directly on the floor.
- The product shall be stored on a plane area. They should not be turned upside down. They should not be placed against the wall.

Shelf Life of CDIL Products

The shelf life of products is the period from product manufacture to shipment to customers. The product can be unconditionally shipped within this period. The period is defined as 2 years.

If products are stored longer than the shelf life of 2 years, the products shall be subjected to quality check as per CDIL quality procedure.

The products are further warranted for another one year after the date of shipment subject to the above conditions in CDIL original packing.

Floor Life of CDIL Products and MSL Level

When the products are opened from the original packing, the floor life will start. For this the following JEDEC table may be referred:

JEDEC MSL Level		
Level	Time	Condition
1	Unlimited	≤ 30 °C / 85% RH
2	1 Year	≤ 30 °C / 60% RH
2a	4 Weeks	≤ 30 °C / 60% RH
3	168 Hours	≤ 30 °C / 60% RH
4	72 Hours	≤ 30 °C / 60% RH
5	48 Hours	≤ 30 °C / 60% RH
5a	24 Hours	≤ 30 °C / 60% RH
6	Time on Label(TOL)	≤ 30 °C / 60% RH

Figure 1 Floor Life according to JEDEC MSL Level



Continental Device India Pvt. Limited

An IATF 16949, ISO9001 and ISO 14001 Certified Company



Customer Notes

Component Disposal Instructions

1. CDIL Semiconductor Devices are RoHS compliant, customers are requested to please dispose as per prevailing Environmental Legislation of their Country.
2. In Europe, please dispose as per EU Directive 2002/96/EC on Waste Electrical and Electronic Equipment (WEEE).

Disclaimer

The product information and the selection guides facilitate selection of the CDIL's Semiconductor Device(s) best suited for application in your product(s) as per your requirement. It is recommended that you completely review our Data Sheet(s) so as to confirm that the Device(s) meet functionality parameters for your application. The information furnished in the Data Sheet and on the CDIL Web Site/CD are believed to be accurate and reliable. CDIL however, does not assume responsibility for inaccuracies or incomplete information. Furthermore, CDIL does not assume liability whatsoever, arising out of the application or use of any CDIL product; neither does it convey any license under its patent rights nor rights of others. These products are not designed for use in life saving/support appliances or systems. CDIL customers selling these products (either as individual Semiconductor Devices or incorporated in their end products), in any life saving/support appliances or systems or applications do so at their own risk and CDIL will not be responsible for any damages resulting from such sale(s).

CDIL strives for continuous improvement and reserves the right to change the specifications of its products without prior notice.



CDIL is a registered Trademark of
Continental Device India Pvt.Limited

C-120 Naraina Industrial Area, New Delhi 110 028, India.

Telephone+ 91-11-2579 6150, 4141 1112 Fax + 91-11-2579 5290, 4141 1119

email@cdil.com www.cdil.com

CIN No. - U32109DL1984PTC004291